

Essential Collection Window Installation

New Wood Frame Construction

These instructions are applicable for the following products:

- Casement Family
- Double Hung Family
- Glider
- Round Tops
- Polygons

ABSTRACT: Please read these instructions in their entirety before beginning to install your Essential window product. These installation instructions demonstrate the installation of Essential windows in new wood frame construction using an industry approved water management system. For installation using other construction methods, such as remodeling, replacement, and recessed openings refer to “ASTM E2112, Standard Practice for Installation of Exterior Windows, Doors and Skylights,” for installation suggestions. Information for ASTM E2112 can be found on the ASTM website, www.astm.org.

For product specific issues, service instructions and other field service guides, visit our website, www.marvin.com or contact your Marvin representative.

Regional standard practices, environmental conditions, and codes may vary and supersede the procedures contained within. The responsibility for compliance is yours: the installer, inspector, and owner(s).

The procedures within these instructions are consistent with those used in testing to achieve the advertised DP rating.

Table of Contents

Before You Begin	1	Step 3: Preparing the Unit for Installation	4
After Market Products	2	Step 4: Installing the Window	7
You Will Need to Supply	2	Step 5: Flashing the Installation	10
Standard Parts Shipped	2	Step 6: Final Installation Procedures	11
Step 1: Rough and Masonry Opening Requirements .	3	Technical Installation Specifications	12
Step 2: Rough Opening Preparation	4		

Before You Begin

- Always provide a copy of these instructions for the current or future building owner.
- Plan sizing of rough opening and clearance from exterior finishing systems to allow for normal materials shrinkage or shifting (e.g. wood structure with brick veneer; allow adequate clearance at sill). Failure to do so can void the Marvin warranty coverage.
- Refer to the Technical Installation Specifications section for technical specifications regarding the installation of this product. These installation requirements as well as the details in this section must be followed to achieve the advertised design pressure (DP) rating of this product.
- It is the responsibility of the builder, installer and subcontractors to protect the interior and exterior of windows or doors from harsh chemical washes, construction material contamination and moisture. Damage to glazing, hardware, weather strip and cladding/wood can occur. Protect with painters tape and/or protective sheathing as required. Follow all guidelines regarding material use, preparation, personal safety and disposal.
- Contact your Marvin supplier if you have any questions regarding product and materials used in manufacturing or questions on replacement parts.

WARNING!

This product can expose you to chemicals including titanium oxide, which is known to the state of California to cause cancer. For more information, go to www.P65Warnings.ca.gov.

WARNING!

This product can expose you to chemicals including methanol, which is known to the state of California to cause birth defects or other reproductive harm. For more information, go to www.P65Warnings.ca.gov.

WARNING!

Always practice safety! Wear the appropriate eye, ear and hand protection, especially when working with power tools.

After Market Products

Alterations to Marvin products including window films, insulating or reflective interior window treatments or additional glazings can cause excessive heat buildup and/or condensation. They may lead to premature failures not covered under warranty by Marvin Windows and Doors.

Before purchasing or applying any product that may affect the installation or performance of Marvin Essential windows contact the manufacturer of after market product/glazings that are not supplied by Marvin and request written product use, associated warranties and damage coverage. Provide this information and warranties to the end user and/or building owner for future reference.

You Will Need to Supply

- Safety glasses
- Level
- Hammer
- 2" Roofing nails
- Tape measure
- Low expansion foam
- Sill pan flashing
- Construction adhesive
- Backing material (foam backing rod)
- Hearing protection
- Square
- Wood shims
- Insulation
- Perimeter sealant
- Flashing Material

Standard Parts Shipped

Units are sent with hardware and four (4) nailing fin corner gaskets. Follow installation instructions included with part, if applicable.

NOTE: Numbers listed in parentheses () are metric equivalents to the nearest whole number.

NOTE: Depending on the installation method, other material may be needed to properly prepare and seal the installation such as self-sealing adhesive flashing, building paper, and seam seal tape, etc.

Step 1: Rough and Masonry Opening Requirements

1. Rough openings (RO) should be a 1/2" (13) wider than the outside measurement of the frame and a 1/2" (13) higher. (When framing rough opening, care should be taken to ensure the sill plate is level and the opening is square, straight and plumb.) See [Figure 1](#).

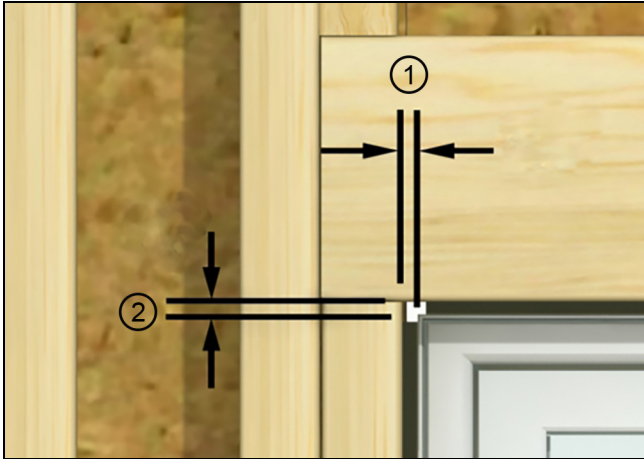

Figure 1

1	1/4" (6)
2	1/2" (13)

2. On shapes such as polygons, round tops, and octagons, make sure there is proper bracing. See [Figure 2](#).



Figure 2

3. Masonry openings (MO) should be 1/2" (13) wider than the outside measurement of the frame or casing and 1/4" (6) higher than the outside measurement of the frame or casing. See [Figure 3](#).

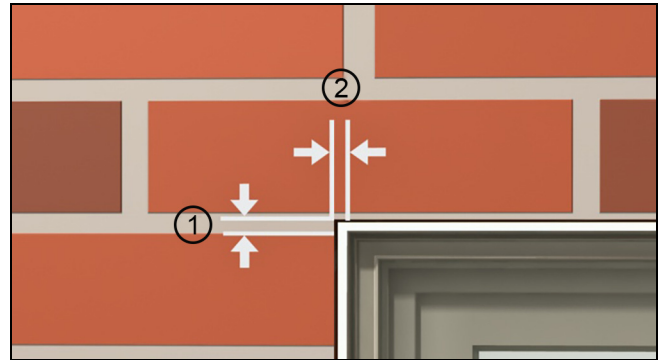

Figure 3

1	1/4" (6)
2	1/4" (6)

NOTE: On standard wood frame construction with brick veneer, make sure there is at least 1/2" (13) between the bottom of the window sill (or eventual placement of the window) and the top of the brick to avoid "brick bind". See [Figure 4](#).



Figure 4

1	1/2" (13)
---	-----------

NOTE: When using a sill panning product you may need to adjust the opening accordingly to account for the height of the panning.

⚠ CAUTION!

If the previous conditions are not met, the installer must take corrective actions to alter the opening(s) before proceeding. It is also essential that the sheathing behind the wall be a solid surface to ensure that the unit can be secured firmly to the wall, commonly found in masonry applications.

Step 2: Rough Opening Preparation

1. The method shown below is Method A1 using a TYPE III flash pan. For step-by-step instructions on how to prepare an opening using this method, refer to www.marvin.com/ROprep for instructions titled

"Window Rough Opening Prep and Flashing Method A1-Membrane Drainage System". Refer to ASTM E2112 for other rough opening preparations that are more appropriate for your situation.

Step 3: Preparing the Unit for Installation

1. Remove the protective packaging from the unit and dispose/recycle properly. Inspect unit for any hidden damage and report immediately to your Marvin representative. Provide the customer service number etched on one of the top corners of the glass. See [Figure 5](#).

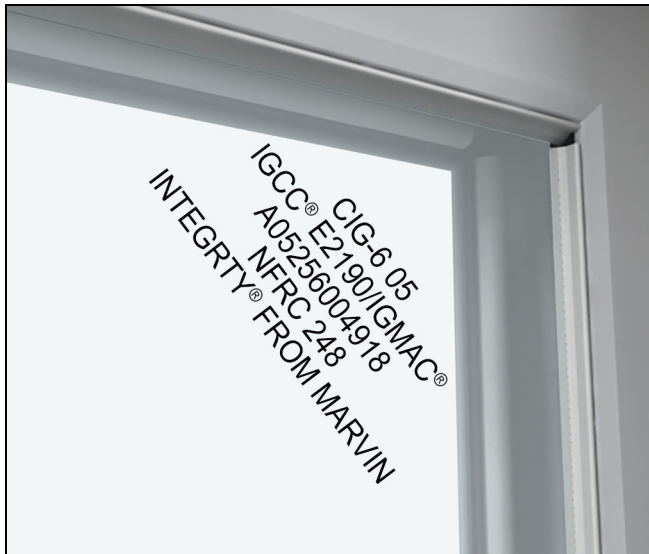

Figure 5

2. Position the factory applied nailing fin in the upright position. DO NOT APPLY NAILING FIN CORNER GASKETS AT THIS TIME.

3. On masonry openings you will need to modify the bracket. Remove the front leg of the bracket by cutting with a metal cutter or similar tool. See [Figure 5](#).

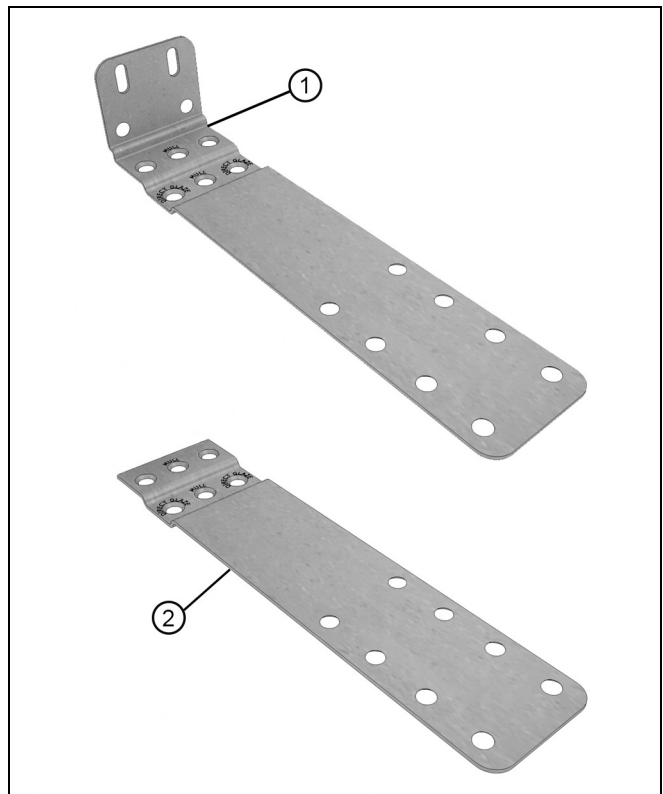

Figure 6

1	Remove front leg for masonry opening application
2	Bracket after modification

4. If you are installing a window with structural brackets apply a 3/16" (5) diameter 1 1/2" (38) long bead of heavy duty construction adhesive in the exterior jamb channel. The adhesive is to be placed 6" (152) in from each corner and spaced 12" (305) apart along the head jamb and jambs of the unit. Press the 90-degree bent structural brackets firmly into place over the adhesive and secure with the two provided screws in the structural bracket kit. See [Figure 7](#), [Figure 8](#) and [Figure 9](#).

IMPORTANT

Do not apply 90-degree bent brackets on sill.

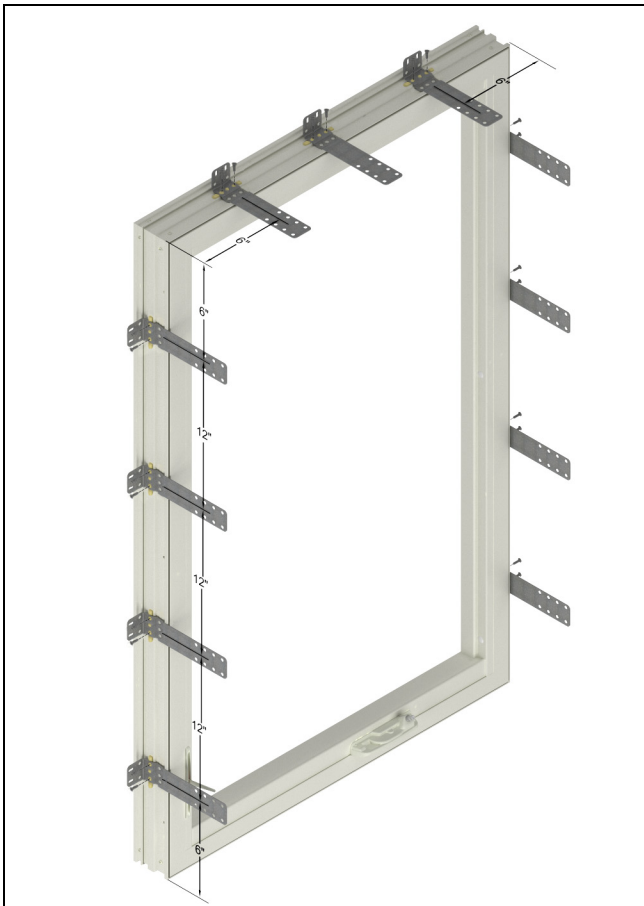

Figure 7

NOTE: Screw placement is different for Direct Glaze versus all other product. The bracket is fastened to the Direct Glaze using the holes closer to the interior (markings on the bracket denote proper screw placement).

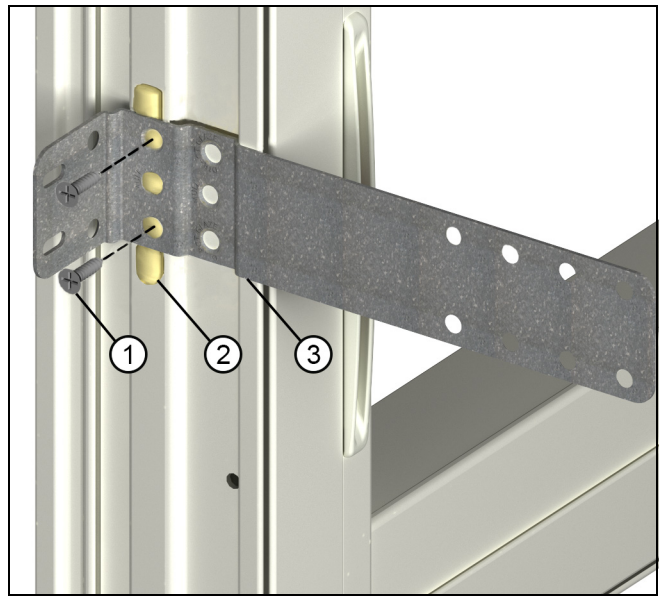

Figure 8 All product except Direct Glaze

1	Screw
2	Sealant
3	90-degree bent structural bracket

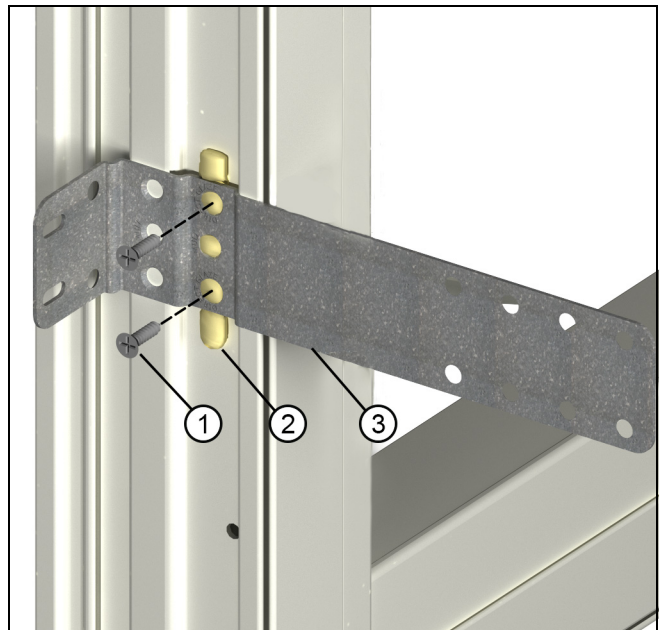

Figure 9 Direct Glaze

1	Screw (using holes closest to interior)
2	Sealant
3	90-degree bent structural bracket

5. Slide flat sill structural brackets into T-slot channel at the sill. Insert enough brackets to ensure a bracket is within 6" of each corner and evenly spaced 12" apart along the sill. Final adjustment of bracket locations should be done once the unit is resting in the opening. See [Figure 10](#).

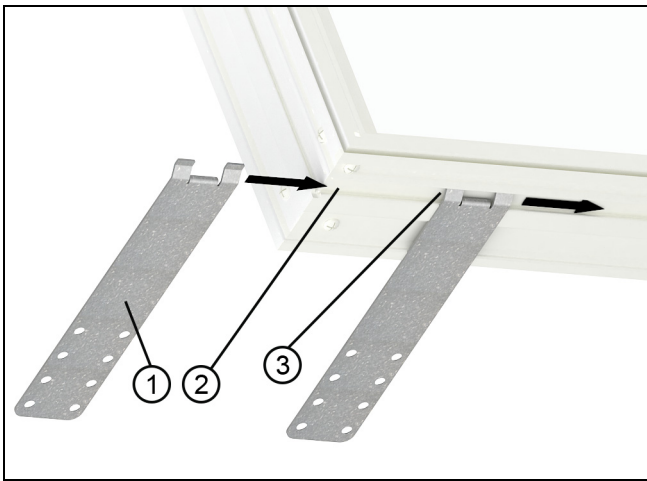

Figure 10

1	Sill structural bracket
2	Slide
3	T-slot

⚠ CAUTION!

Do not use fasteners to attach brackets to the sill. Puncturing the sill with fasteners may create a penetration point for water to leak into the rough opening and may void your warranty.

6. For installing a factory mulled unit, apply 90-degree bent structural brackets 1 1/8" from the mullion on both sides of all jamb and head jamb mullion joints. This applies to nail fin or structural bracket installation. See [Figure 11](#). For sill mullion joints, slide flat sill structural brackets into sill T-slot and position one on either side of each mullion joint. If mulled assembly has nailing fin, remove the nailing fin at the sill prior to sliding brackets on. Cut sill nail fin at each mullion joint location and shorten the ends by 3"-3.5" near each mullion to allow for the brackets. Slide brackets and nail fin pieces into the sill T-slot. See [Figure 12](#).

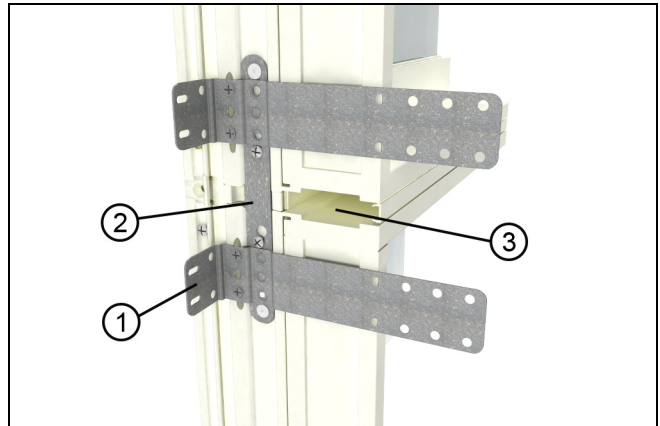

Figure 11

1	90-degree bent structural bracket
2	Mull bracket
3	Mull

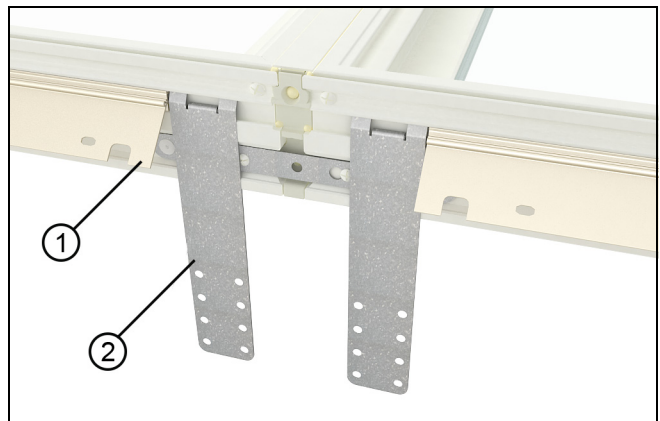

Figure 12

1	Nail fin
2	Sill structural bracket

7. For mulls with 1/2" mull reinforcement, remove existing shipping screw and apply third 90-degree bent structural bracket to center of each mullion joint (including sill mullion joints) with two #8 x 2" screws. See [Figure 13](#) (for jamb) and [Figure 14](#) (for sill).

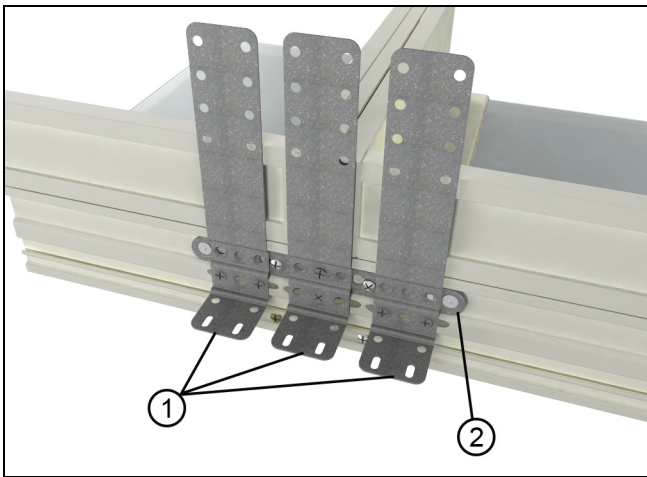

Figure 13 At jamb

1	90-degree structural bracket
2	Mull bracket

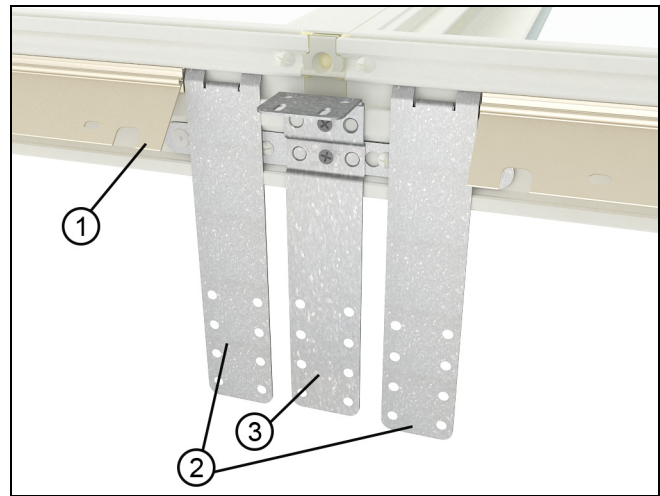

Figure 14 At sill

1	Nail fin
2	Structural brackets
3	90-degree bent structural bracket

8. Install jamb extension before installing the window in the rough or masonry opening. Follow instructions provided with the jamb extension.

! CAUTION!

Unlocked windows can open during installation causing damage to the window unit or personal injury. Keeping the window locked will assist in keeping it square until fastened in the opening.

Step 4: Installing the Window



Seek Assistance

Some large windows and/or assemblies are very heavy. Avoid injury by getting help to lift and position the window into the rough opening.

1. Center the window in the opening. Level at the sill and plumb the frame (interior/exterior). Shim under the sill to bring to level if necessary. See [Figure 15](#).

NOTE: Depending on construction method or wall type, you may need to modify the clip/bracket to fit the opening. Fastening holes should be no more than 1/4" (6) from the bend in the bracket. If necessary, drill two 5/32" (3) holes in the bracket

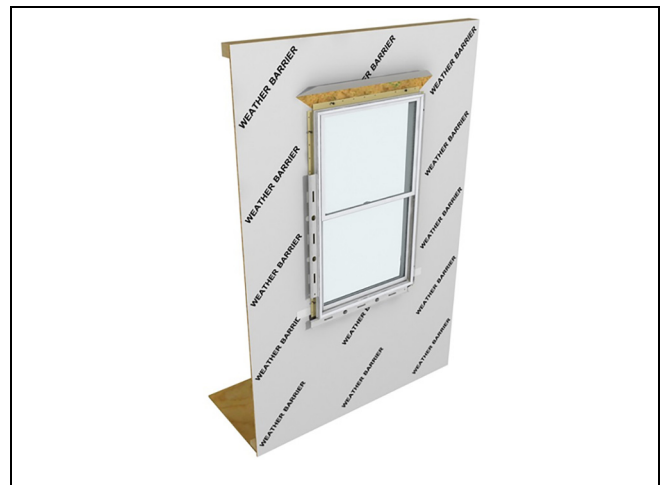

Figure 15

2. Once level, tack the jambs with 2" (51) roofing nails within 6" (152) from the head jamb (or fasten top brackets). See [Figure 16](#).



Figure 16

! CAUTION!

Do not screw or nail through the Ultrex frame. Damage will occur and may void your warranty.

3. From the interior, square the frame in the opening by installing shims between the jambs and framing 4"-6" (102-152) from the head jamb and sill. Measure the diagonals and adjust shims until the unit is square in the opening. See [Figure 17](#).



Figure 17

4. Tack the lower corners of the nailing fin and recheck for square. If necessary, remove the nails and adjust shims until the unit is square. See [Figure 18](#).



Figure 18

! CAUTION!

Proper shimming is extremely important. Under-shimming or over-shimming will result in bowed jambs and or head jamb. Both conditions can contribute to improper window operation.

ATTENTION

For units installed with masonry clips or structural brackets. Bend bracket around framing member and attach with the #8 x 1 1/4" screws. Angle screws approximately 15° away from the window. Always shim above or below brackets. See [Figure 19](#).



Figure 19 Attaching window with structural brackets.

5. Recheck the diagonals one more time to make sure the unit is square in the opening. If square install additional shims at 15" intervals on center and at each lock point. Always shim at check rails and meeting stiles. See [Figure 20](#).



Figure 20

6. On round tops and other non-rectangular shapes, make sure to shim at bracing locations. See Figure 21.



Figure 21

1	Shim locations
---	----------------

7. Measure at head jamb, center of unit, and sill to make sure all dimensions are equal. If they are not, you will have to adjust the shims accordingly. See Figure 22.

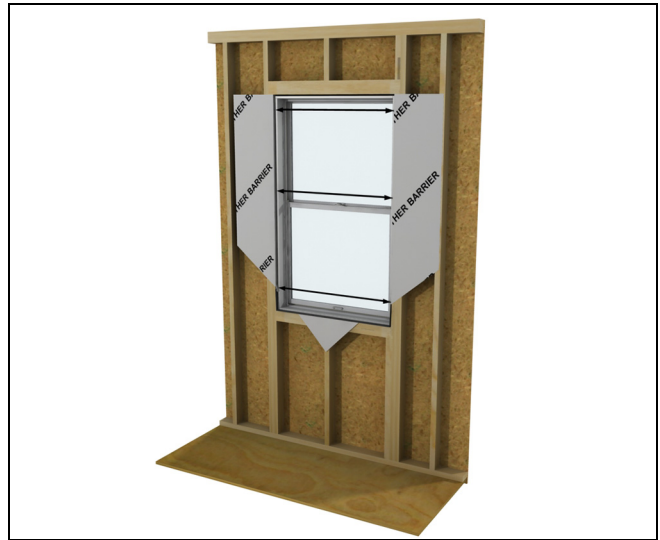

Figure 22

8. Once the unit is square and plumb in the opening, operate the sash (on operable units) to make sure it is operating properly. If not, you may have to make some adjustments to the shims.

Tip

On operating units, one way to make sure that the unit is installed square is to check the reveal (gap) between the operating sash and the frame. An even reveal around the entire sash generally means a squarely installed unit and will ensure smooth operation.

9. Complete fastening of the nailing fin around the perimeter of the unit with 2" roofing nails 6" (152) from each corner and spaced every 6"-8" (152-203) on center (or fasten remaining structural brackets).

CAUTION!

If building codes require foam type insulation to form an infiltration seal, use only low expansion type foam in combination with fiberglass insulation. Foam and foam application must conform to ASTM E2112. Follow all instructions and warnings from the foam manufacturer.

10. Apply nail fin corner gasket to each corner. Follow instructions on the back of the gasket.

11. Insulate loosely around the window with fiberglass insulation.

12. Integrate the unit with the interior air barrier of the structure by inserting backer rod into the RO and applying a continuous bead of sealant around the interior perimeter of the unit. See [Figure 23](#).

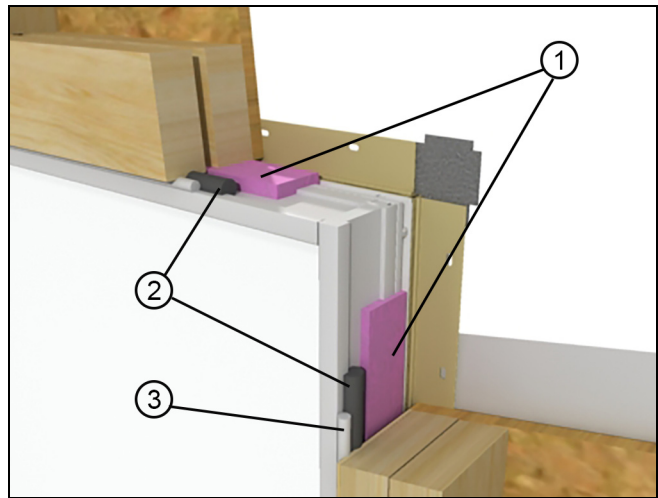

Figure 23

1	Fiberglass insulation
2	Backer rod
3	Sealant

Step 5: Flashing the Installation

1. Flash the installation in a weather board fashion. For step by step instructions refer to marvin.com/ROprep for instructions titled "Window Rough Opening Prep and Flashing Method A1-Membrane Drainage System".



Figure 24

Step 6: Final Installation Procedures

1. Install exterior finish or siding per manufacturer's instructions.
2. After exterior finish or siding is installed, apply sealant around the exterior perimeter of the unit frame or casing. As needed, insert backing material between the frame or casing and the structure to provide a proper sealant joint. Sealant depth must be equal to width between unit and exterior finish material (brick and masonry apply). Always refer to the manufacturers' recommendations for proper surface preparation and application. See [Figure 25](#).



Figure 25

1	Backer
2	Sealant

⚠ CAUTION!

Perimeter sealant must be Grade NS Class 25 per ASTM C920 and compatible with the window product and the finished exterior(s) of the building. Using improper sealant could result in sealant failure causing air and water infiltration

⚠ CAUTION!

Take care to keep sealant away from drain weeps in lower corners of sliding window products. Drain weeps must be kept clear to permit proper water performance and drainage. See [Figure 26](#).

3. For J-Channel installation, refer to the installation instruction included with the J-Channel for [regular](#) and [adjustable](#) corner key applications.



Figure 26

1	Drain weep
---	------------

4. On Single and Double Hung units: Raise the bottom sash and tilt in. Remove the vinyl shipping blocks from each side. See [Figure 27](#).

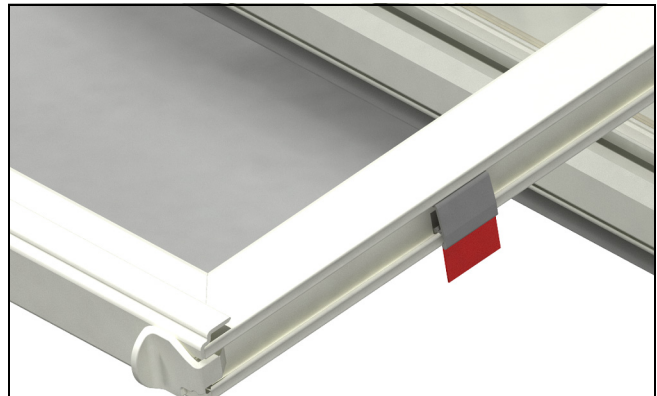

Figure 27

NOTE: Sash must be raised at least 1" (25) before tilting to avoid damaging weather strip or sill components.

5. On Casement units: Open the sash and remove the shipping blocks from the frame. See [Figure 28](#).

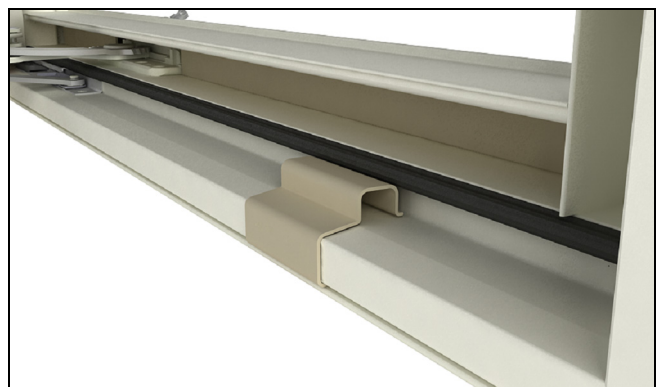

Figure 28

Technical Installation Specifications

The following details are specified for proper installation and for the unit to meet the advertised design pressure (DP) rating.

- Rough Opening Width: 1/4"-1" (6-25) wider than window/door frame outside measurement.
- Rough Opening Height: 1/4"-1/2" (6-13) higher than window/door frame outside measurement.
- Masonry Opening Width: 1/4"-1/2" (6-13) wider than window/door frame outside measurement.
- Masonry Opening Height: 1/8"-1/4" (3-6) higher than window/door frame outside measurement.

Architectural Detail Manual Specifications:

- Rough Opening: Width 1/2" (13); Height 1/2" (13).
- Masonry Opening: Width 1/2" (13); Height 1/4" (6).
- The panning must drain water to the exterior of the cladding OR the exterior surface of a concealed weather resistive barrier.

- Shim 4"-6" (102-152) from each corner on jambs and head jambs. Install additional shims at 15" (381) on center and at all locking points. Always shim at the checkrails and meeting stiles.
- Do not use chemically treated products for shim material.
- Fasten units installed with nailing fin to the sheathing with 2" (51) galvanized roofing nails spaced no more than 4" (102) from each corner and spaced no more than 8" (203) on center around the entire perimeter.
- Fasteners penetrating chemically treated lumber must be a minimum of 0.90 oz/ft² zinc hot dipped galvanized or stainless steel type 304 or 316.
- The window frame must not come into direct contact with chemically treated wood products.

NOTE: The unit was finished with a wood trim to simulate a finished installation during certification testing.

CAUTION!

Be aware that the use of sill pans and other barriers will decrease the rough opening height clearance. Adjust opening dimensions accordingly.

- The panning system used in these instructions is one component in a structure's overall water management system. It should be used in conjunction with an appropriate drainage plane compatible with the exterior cladding.
- Flashing materials must comply with ASTM E2112 and be compatible with all materials used in installation including panning systems, air barriers and building papers, sheathing, and the window unit.
Flashing material must not contain asphalt and must be compatible with flexible PVC (vinyl).
- Properly flash and/or seal all windows at the exterior perimeter.
- Sealants used for installation must be Grade NS Class 25 per ASTM C920 and compatible with the building exterior, window exterior surface, and flashing/water management materials.
- Optional foams used for installation must be low expansion only. Foam and foam application must comply with ASTM E2112.